



## Film Capacitors – Power Factor Correction

### Thyristor Module TSM-LC-N1

<b>Series/Type:</b>	<b>TSM-LC-N1</b>
<b>Ordering code:</b>	<b>B44066T3850E402</b>
Date:	2016-02-08
Version:	1

© EPCOS AG 2016. Reproduction, publication and dissemination of this publication, enclosures hereto and the information contained therein without EPCOS' prior express consent is prohibited.

EPCOS AG is a TDK Group Company.

**Preliminary data**
**General**

The TSM-LC-N1 for Dynamic PFC is a fast electronically controlled, self-observing thyristor switch for capacitive loads up to 50 kvar (380...440 VAC) which is capable to switch PFC capacitors within a few milliseconds as often and as long as required without abrasion.

Triggering can be done by means of dynamic power factor controllers, programmable logic controllers (PLC) or directly out of the technologic process.

- Thyristor module for dynamic compensation systems in grids from 380 to 440 V, 50/60 Hz, for 25 to 50 kvar
- Follow-on development TSM-LC-N
- Optimized switching behaviour by micro-processor controlled alignment to capacitor branches with or without detuning reactor
- No wear-out parts (no fan)
- Monitoring of voltage, phase and temperature; status via LEDs
- Switching without delay
- No auxiliary voltage required
- Maintenance free, long service life
- Enhanced connection via clamps
- Enhanced temperature management

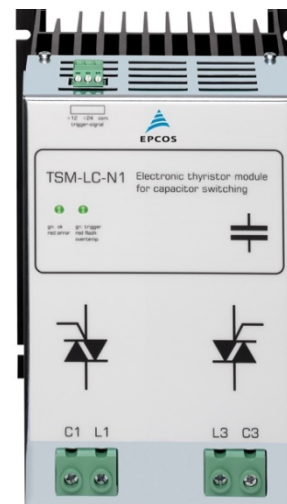
**Applications:**

Dynamic compensation in fast processes:

- Presses
- Welding machines
- Elevators
- Cranes
- Wind turbines

**Preliminary data**
**Mounting and connection**

The mechanical mounting is done directly on a mounting plate. The main terminals can be directly connected via lines to the main fuse resp. capacitor. (max. 35 mm<sup>2</sup>).

Connection is done according picture 1. It is mandatory to use superfast electronic fuses as branch fuses to protect the semiconductor device! Basics of dimensioning must be obeyed!

Triggering of the module is taking place without any time delay by a 10 – 24 VDC signal (coming from the PFC-controller or an adequate control system) fed in at the connection X1 (signal).

If an increase of the stage output is needed, a cascading of several modules is possible.

**Putting into operation**

After switching on the net voltage (engaging of the branch fuse) the thyristor module is ready for operation.

The thyristor module has 2 status-LEDs with the following meaning:

**LED - left side**

Green:	operating voltage activated, thyristor module standby
Red permanent:	capacitor without capacitance or not existant; thyristor or fuse defect
Red flashing:	net voltage L1/L3 missing or too low

**LED - right side:**

Green:	„Module ON“ (Trigger)
Red flashing:	over-temperature

**Preliminary data**

Technical data and specifications	
Net voltage	380 ... 440 V
Frequency	50/60 Hz
Max. power	Max. 75 A (up to 50 kvar/400 V)
Activation	10 ... 24 V DC (approx.. 10 mA) via terminal clamp, internally insulated
Switching-on time	Approx. 5 ms
Re-switching time	Depending on degree of de-tuning and dimension of discharge resistor
Display	Via 2 LEDs
Monitoring	Permanent monitoring of net voltage, real current, temperature and operation status. Before re-switching after temperature fault, heat sink temperature must be below 50 °C (hysteresis)!
Power circuit	Direct connection 4-pole via high current clamps (cable lug 35 mm <sup>2</sup> ). Connection from bottom.
Max. RMS-current	100 A; no continuous current –thermal load has to be considered!
Power dissipation	$P_v (W) = 2.0 \times I$ (in A); at 400 V/50 kvar typical 150 W
Max. voltage	440 V
Fuses	3 x electronic fuse “superfast” (NH AC 690 V) 50 kvar: 125 A (e.g. SIBA Art.No.: 20 209 20-125) 25 kvar: 63 A (z.B. SIBA Art.Nr.: 20 477 20-63)
Dimensions (in mm)	157 x 200 x 180 (w x h x d)
Weight	4.8 kg
Assembling	Direct mounting on mounting plate
Mounting position	Vertical, minimum 150 mm distance upwards and downwards
Operating temperature with nominal load	-10 ... 55 °C

Preliminary data

Connection diagrams

Pict 1: three phase load (standard)

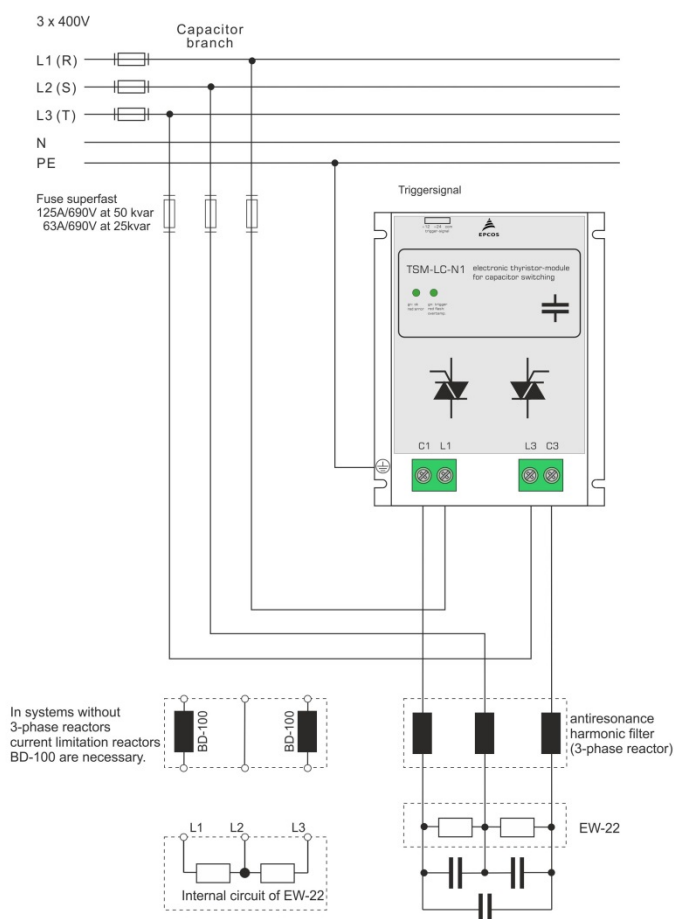

Pict. 2: two phase load

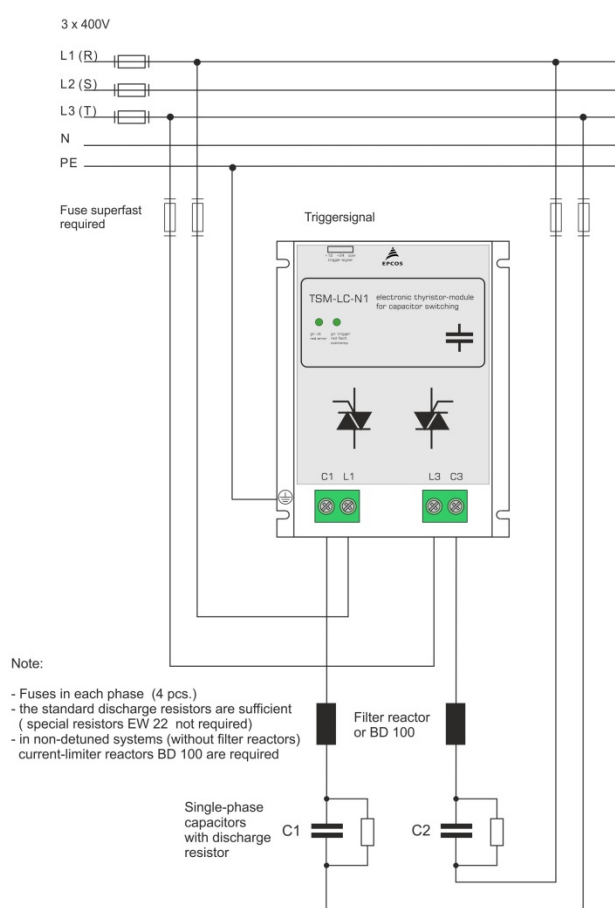

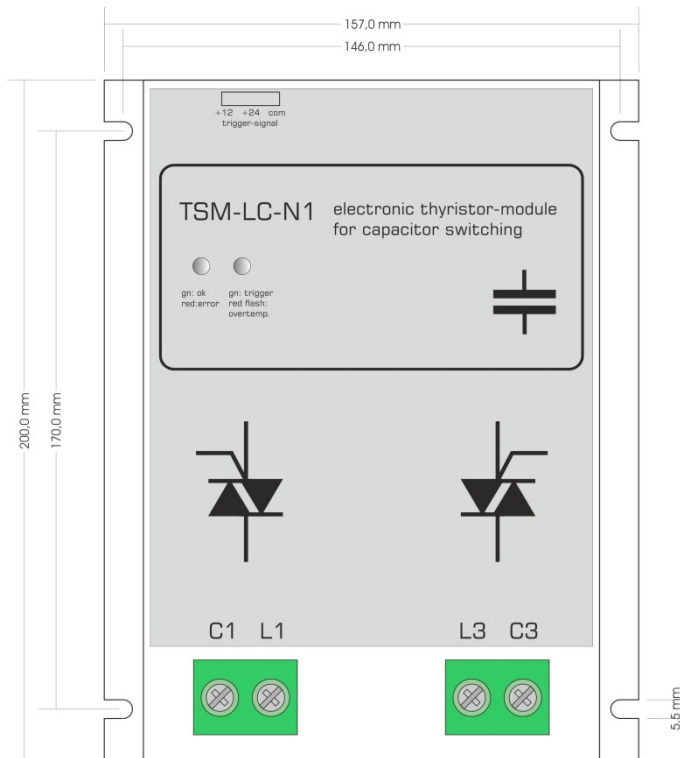
**Preliminary data**
**Pict. 3: Dimensions TSM-LC-N1**

**Cautions and warnings**
**Attention: Please follow SAFETY INSTRUCTIONS !**

- The TSM-LC thyristor-modules may only be used according their intended utilization.
- The TSM-LC thyristor-modules must only be used in combination appropriate safety devices (e.g. superfast fuses).
- The TSM-LC thyristor-modules have to be projected in such a way that no uncontrolled high currents and voltages can occur in case of faults.
- The devices have to be protected against humidity and dust – a sufficient ventilation has to be assured.
- The TSM-LC thyristor-modules must only be switched to the net if any harm or danger to human beings or the PFC-system is eliminated.

### Preliminary data

Due to the switching principle of the thyristor modules the PFC-capacitors are permanently loaded at the peak value of the grid voltage (DC current) even when they are disconnected! Therefore, the following instructions have to be obeyed:

- In non-detuned systems (400 V grid) capacitors with a voltage of 440 V are needed!
- In detuned systems (400 V grid) capacitors with a voltage of 480 V are needed!
- For discharging the capacitors special high-voltage resistors are required (e.g. type EW22) Standard resistors cannot be used.
- In dynamic PFC-systems with TSM-LC thyristor-modules fast discharge reactors must not be used (reactor = direct current short circuit).
- In non-detuned PFC-systems (without reactors) 2 current limitation reactors per thyristor-module are mandatory! Available as accessory (BD100).
- The TSM-LC-thyristor modules have to be protected by superfast electronic fuses in any case. Dimensioning principles have to be observed. Fuses in the PFC-system must be marked!
- Due to the special switching the PFC-capacitors are fully loaded even if the step is switched off. An appropriate protection against touch must be assured!
- Even when electronic switches are turned off, no electrical isolation is given. Therefore even after switching off the complete PFC-system (main circuit breaker), parts of the PFC-system must only be touched after the discharge-time of the PFC-capacitor elapsed.
- In the PFC-system warning signs indicating the presence of residual voltage even at disconnected stage have to be visible.

### Maintenance, repair

The TSM-LC thyristor-switch has to be deactivated for maintenance purpose and main circuit breaker must be released. It must be assured that it cannot be switched on during maintenance. It must be checked that there is no voltage at all. Maintenance must only be executed by specially skilled personnel.

In case any repairs are needed, this must only be done from the manufacturers of the TSM- thyristor-module!

- Do not install the reactor in case of any visible damages.
- Installation must be done by skilled personnel only.
- Do not use or store harmonic filter reactors in corrosive atmosphere, especially where chloride gas, sulphide gas, acid, alkali, salt or similar substances are present.
- Do not touch the device during operation: all electrically active parts of this equipment such as windings, electronic components, leads, fuses and terminals carry a dangerous voltage which can lead to burns or electric shock.
- Covers which protect these electrically active parts from being touched must not be opened or removed during operation.
- Before any assembly or maintenance work is started, all installations and equipment must be disconnected from the power source.
- Noncompliance with these instructions may lead to death, serious injury or major damage to equipment.

FAILURE TO FOLLOW CAUTIONS MAY RESULT, WORST CASE, IN PREMATURE FAILURES OR PHYSICAL INJURY.

### Note

For detailed information about PFC capacitors and cautions, refer to the latest version of EPCOS PFC Product Profile.

## Important notes

The following applies to all products named in this publication:

1. Some parts of this publication contain **statements about the suitability of our products for certain areas of application**. These statements are based on our knowledge of typical requirements that are often placed on our products in the areas of application concerned. We nevertheless expressly point out **that such statements cannot be regarded as binding statements about the suitability of our products for a particular customer application**. As a rule, EPCOS is either unfamiliar with individual customer applications or less familiar with them than the customers themselves. For these reasons, it is always ultimately incumbent on the customer to check and decide whether an EPCOS product with the properties described in the product specification is suitable for use in a particular customer application.
2. We also point out that **in individual cases, a malfunction of electronic components or failure before the end of their usual service life cannot be completely ruled out in the current state of the art, even if they are operated as specified**. In customer applications requiring a very high level of operational safety and especially in customer applications in which the malfunction or failure of an electronic component could endanger human life or health (e.g. in accident prevention or life-saving systems), it must therefore be ensured by means of suitable design of the customer application or other action taken by the customer (e.g. installation of protective circuitry or redundancy) that no injury or damage is sustained by third parties in the event of malfunction or failure of an electronic component.
3. **The warnings, cautions and product-specific notes must be observed.**
4. In order to satisfy certain technical requirements, **some of the products described in this publication may contain substances subject to restrictions in certain jurisdictions (e.g. because they are classed as hazardous)**. Useful information on this will be found in our Material Data Sheets on the Internet ([www.epcos.com/material](http://www.epcos.com/material)). Should you have any more detailed questions, please contact our sales offices.
5. We constantly strive to improve our products. Consequently, **the products described in this publication may change from time to time**. The same is true of the corresponding product specifications. Please check therefore to what extent product descriptions and specifications contained in this publication are still applicable before or when you place an order. We also **reserve the right to discontinue production and delivery of products**. Consequently, we cannot guarantee that all products named in this publication will always be available. The aforementioned does not apply in the case of individual agreements deviating from the foregoing for customer-specific products.
6. Unless otherwise agreed in individual contracts, **all orders are subject to the current version of the "General Terms of Delivery for Products and Services in the Electrical Industry" published by the German Electrical and Electronics Industry Association (ZVEI)**.
7. The trade names EPCOS, Alu-X, CeraDiode, CeraLink, CeraPad, CeraPlas, CSMP, CSSP, CTVS, DeltaCap, DigiSiMic, DSSP, ExoCore, FilterCap, FormFit, LeaXield, MiniBlue, MiniCell, MKD, MKK, MotorCap, PCC, PhaseCap, PhaseCube, PhaseMod, PhiCap, PQSine, SIFERRIT, SIFI, SIKOREL, SilverCap, SIMDAD, SiMic, SIMID, SineFormer, SIOV, SIP5D, SIP5K, TFAP, ThermoFuse, WindCap are **trademarks registered or pending** in Europe and in other countries. Further information will be found on the Internet at [www.epcos.com/trademarks](http://www.epcos.com/trademarks).